

Relays

LMDC

High DC voltage relay
7A/110VDC ~ 25A/36VDC range

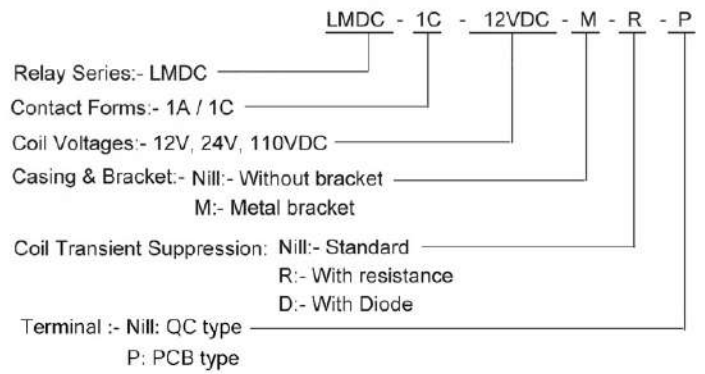

Model		LMDC			
Features	Dimension L * W * H (mm)	32×26.5×23.5mm			
	Terminal Type	QC Type / PCB type			
	Weight	65 gm approx.			
Contact Data	Contact Form	1A / 1C			
	Contact Material	Ag alloy			
	Contact Capacity	7A/110VDC, 15A/72VDC, 20A/48VDC, 25A/36VDC			
Coil Data	Coil Voltage (DC)	12VDC, 24VDC, 110VDC			
	Coil Power Consumption	1.8W			
	Coil Specification	Coil Voltage	Coil Resistance (Ω) ±10%	Pull in Voltage (VDC) Max.	Drop Out Volt (VDC) Min.
		12 VDC	80	7.8V	1.2V
24 VDC	320	15.6V	2.4V		
General Data	Dielectric Strength	500 VAC @ 50 Hz / Min(Between Open Contacts)			
		750VAC@ 50 Hz / Min (Between Coil & Contacts)			
	Insulation Resistance	100 MΩ min. (at 500VDC)			
	Electrical Life	1 x 10 ⁵ cycles (7A/110VDC, 15A/72VDC, 20A/48VDC, 25A/36VDC)			
	Mechanical Life	1 x 10 ⁶			
	Operating Temperature	Standard:- - 40 °C ~ + 85°C			
Appliation	Motor forklift, Accessory relays for high voltage system, air conditioner, electric control system of electromobile & others				

Unit:- mm

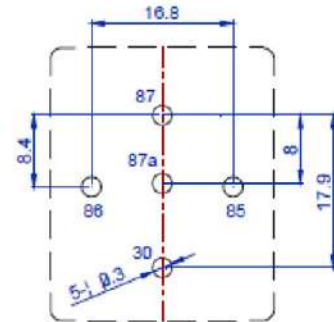
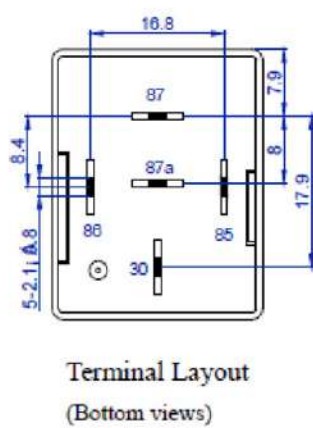
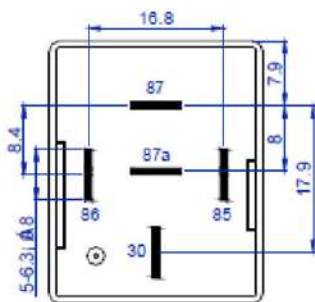
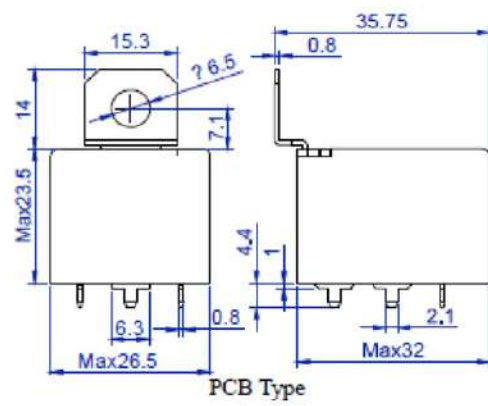
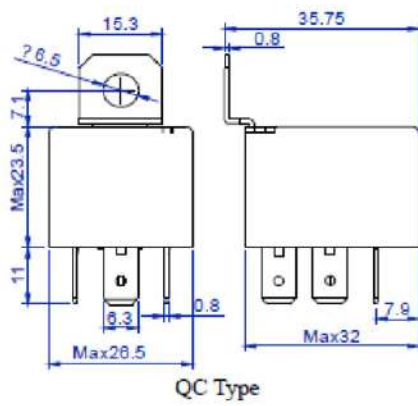

Wiring diagram (Bottom views)

