

Main Feature

1. Epoxy molded Dual-In-Line package.
2. Low profile, mounting space compatible with DIP IC.
3. Completely washable.
4. Provide high speed, miniature and cost effective switching solution.
5. Comply with RoHS and REACH regulations



Contact Rating

Load Type	DIR/DID	
	DIR	DID
Rated Load (Resistive)	0.5A 100VDC	0.2A 30VDC
Rated Carrying Current	0.5A	0.2A
Max. Allowable Voltage	100 VDC	30 VDC
Max. Allowable Current	0.5A	0.2A
Max. Allowable Power Force	10 VA	3 VA
Min. Switching Load	DC 1V, 1mA	DC 1V, 1mA
Contact Material	Rh Alloy	Rh Alloy
Contact Form	SPST/DPST	SPDT

Application

Security System, Modem and Telecommunication Products

Performance (at Initial Value)

- Contact Resistance 150 mΩ Max. @
100mA, 6VDC
- Operate Time 0.5 mSec. Max.
- Release Time 0.5 mSec. Max.
- Dielectric Strength:
Between Coil & Contact..... 1,400 VDC
4,000 VDC (4 Lead)
- Insulation Resistance: 100 MΩ Minimum
Between Contacts 200 VDC

- Temperature Range:
Operating-40~+85 °C
Storage.....-55~125 °C
- Humidity Range.....45~85% RH.
- Vibration20 G
- Shock100 G
- Life Expectancy:
Electrical.....10⁸ Operations at
ref. 10VDC, 10mA
- Weight.....About 1.8g

Safety Standard & File Number

- UL & C-UL.....E141060

Coil Specification (at 20 °C)

Coil Sensitivity	Nominal Voltage (VDC)	Nominal Current (mA)	Coil Resistance ($\Omega \pm 10\%$)	Power Consumption (mW)	Pull-In Voltage (VDC)	Drop-Out Voltage (VDC)	Maximum Allowable Voltage (VDC)
1A	5	10	500	50	3.75	0.8	16
	12	12	1,000	144	9.00	1.0	20
	24	11	2,150	268	18.00	2.0	32
2A	5	36	140	179	3.75	0.8	11
	12	24	500	288	9.00	1.0	20
	24	11	2,150	268	18.00	2.0	32
1B	5	10	500	50	4.20	0.6	6
	12	12	1,000	144	9.00	1.0	14.5
	24	11	2,150	268	18.00	2.0	29
1C	5	25	200	125	3.75	0.8	11
	12	24	500	288	9.00	1.0	20
	24	11	2,150	268	18.00	2.0	32

Ordering Information

DIR - S 4 - 1 05 A

Contact Form: A: One Form A
B: One Form B
C: One Form C

Coil Voltage: 05: 5V, 12: 12V, 24: 24V

Number of Pole: 1: One Pole
2: Two Poles (Make Contact Only)

Lead Number: 4: 4 Leads
8: 8 Leads

Terminal shape: S: Standard (DIP)
C: Lead 2 & 13 are connected (DIP)
M: Standard (SMD)
N: Lead 2 & 13 are connected (SMD)

Type: DIR: Without Diode
DID: With Diode

Classification

Model	DIR/DID							
Terminal shape	DIP				SMD			
Lead 2 & 13	Connected		Disconnected		Connected		Disconnected	
Lead Type	4 Leads	8 Leads	4 Leads	8 Leads	4 Leads	8 Leads	4 Leads	8 Leads
Contact Form	-	1A/1B/1C/2A	1A	1A/1B/1C/2A	-	1A/1B/1C/2A	1A/1B/1C/2A	1A/1B/1C/2A
Ordering Type	-	DIR-C8-1□□A DIR-C8-1□□B DIR-C8-1□□C DIR-C8-2□□A DID-C8-1□□A DID-C8-1□□C DID-C8-2□□A DID-C8-1□□B	DIR-S4-1□□A DID-S4-1□□A	DIR-S8-1□□A DIR-S8-1□□B DIR-S8-1□□C DIR-S8-2□□A DID-S8-1□□A DID-S8-1□□C DID-S8-2□□A DID-S8-1□□B	-	DIR-N8-1□□A DIR-N8-1□□B DIR-N8-1□□C DIR-N8-2□□A DID-N8-1□□A DID-N8-1□□C DID-N8-2□□A DID-N8-1□□B	DIR-M4-1□□A DID-M4-1□□A	DIR-M8-1□□A DIR-M8-1□□B DIR-M8-1□□C DIR-M8-2□□A DID-M8-1□□A DID-M8-1□□C DID-M8-2□□A DID-M8-1□□B

Dimension ($\leq 5\text{mm} \pm 0.2\text{mm}$, $> 5\text{mm} \pm 0.3\text{mm}$, the tolerance of PCB thru hole: $+0.1\text{mm}$)

DIP

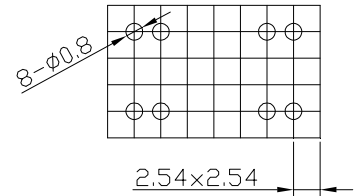
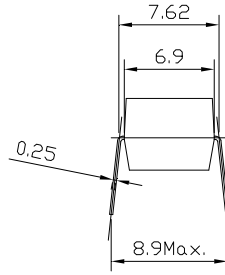
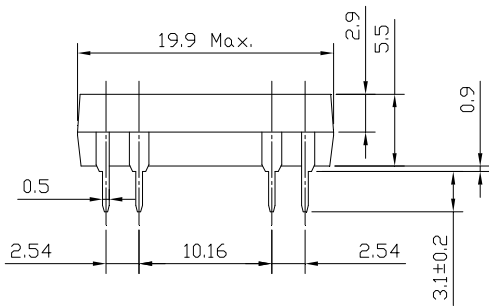

P.C.B. Layout

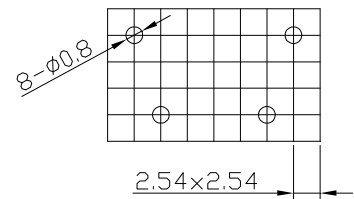
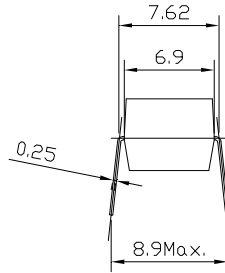
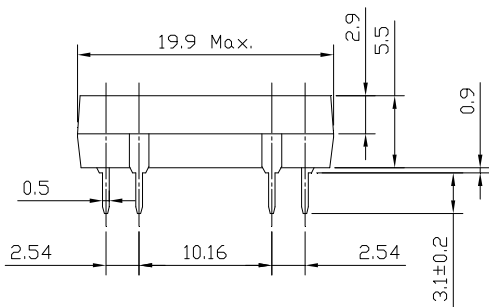

P.C.B. Layout

SMD

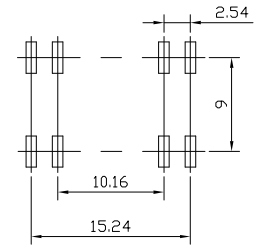
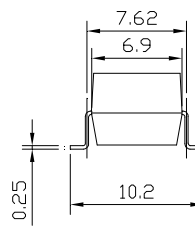
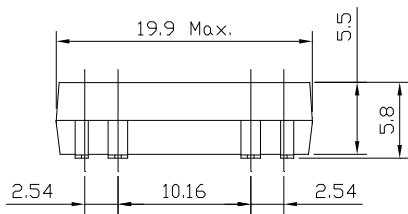

P.C.B. Layout

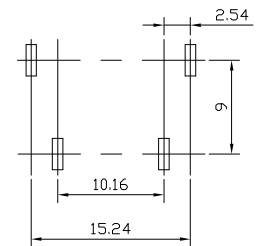
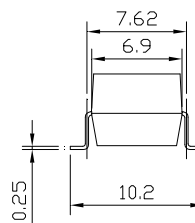
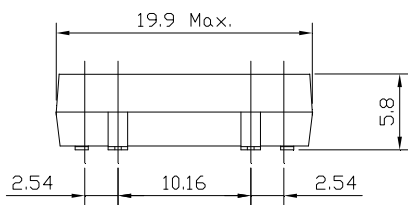

P.C.B. Layout

Wiring Diagram

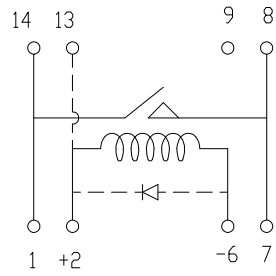

(1 form A)

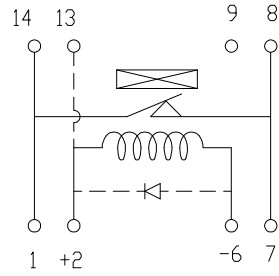

(1 form B)

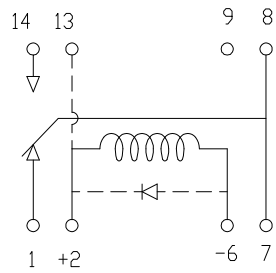

(1 form C)

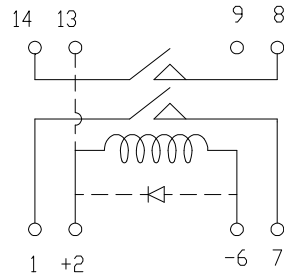

(2 form A)

